

RGB/RGBW neon lights with installation instructions

⚠ WARNING !

The following safety precautions are intended to prevent any injury or damage to other things, and may cause damage if the product violates precautions during use.

1. Installation and inspection of the product must be carried out by a professional with an electrician's certificate.
2. Please use DC24V power supply. Please insure right positive and negative connection. Do not use other power sources, such as AC220-240V.
3. All power cables should be with protection treatment. The power supply wiring should be insulated and waterproof.
4. The product should not be covered thermal insulation material or inflammables, which may cause the product to malfunction or catch fire.
5. The installation must be firm, without loosening, sagging, etc., and the product cannot be moved forcibly after installation.
6. For safety, do not look directly at the LED light source.
7. Do not use as task illumination when in building construction.
8. LED module can't be changed.

PRECAUTIONS

Precautions for storage:

1. storage temperature and humidity: 0°C-55°C 40-70%RH
2. Do not unwarp packaging during storage. Please place in the direction indicated by the carton. Do not stack heavy objects on the packing box.
3. Please do not store the product under the following conditions:
 - High humidity
 - High temperature
 - confetti and dust
 - sunlight exposed
 - Chemicals such as strong acids, strong bases, solvents, etc

Precautions for installation and use:

1. Install in strict accordance with the instructions.
2. temperature of product use: -10°C-+40°C. Do not use under the following conditions:
 - High temperature
 - high humidity,
 - dust,
 - sun exposure,
 - strong acid and strong alkali solvents,
 - >2000 meters high altitude,
 - high air pressure,
 - electromagnetic influence,
 - places that may cause vibration or fall
3. Random cutting, breakage, forcibly pull, twist, press and tag on the product is prohibited.

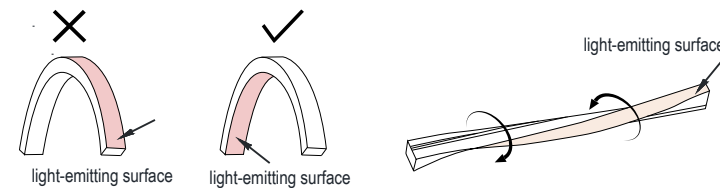

2.

Image 1

The minimum bending radius R of the light strip is shown in Table 1

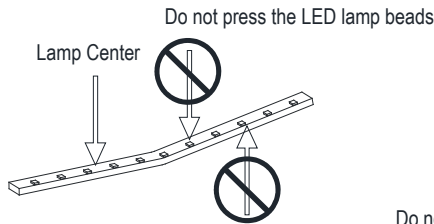

Prohibit the side pressure lamp beads

Image 3

List 1 of minimum bending radii for various specifications of light strips:

Specifications(mm)	8x12	12x16	10x20	10x10	15x15	15x18	16x19	20x20
Minimum bending radius(mm)	50	110	110	50	110	110	110	110

I Mounting

1. Straight Installation

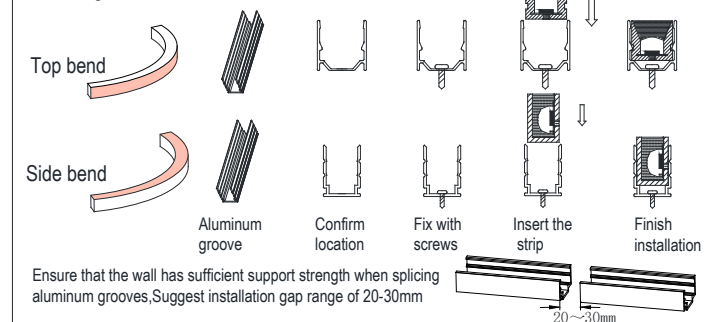

3.

Image 2

Twist angle needs to be $\lt; 360^\circ/m$

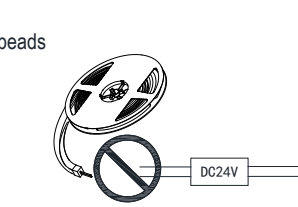

Do not energize the light strips in the reel or when there are other entanglements.

Image 4

2. Curved Installation

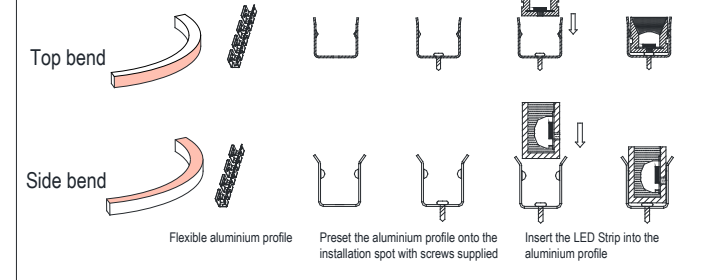

II Cutting

1. If you need to cut, the method is as follows

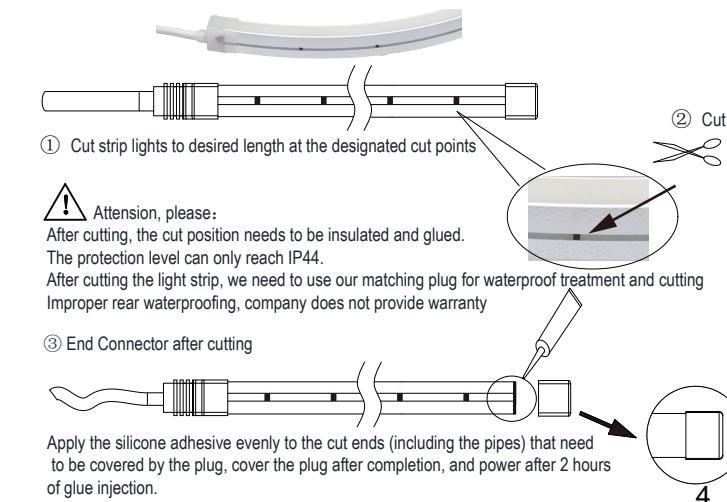

III Wiring connections

1. RGB/RGBW strip light

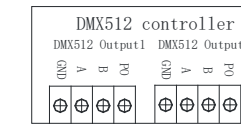

DMX512 Signal Input Connector

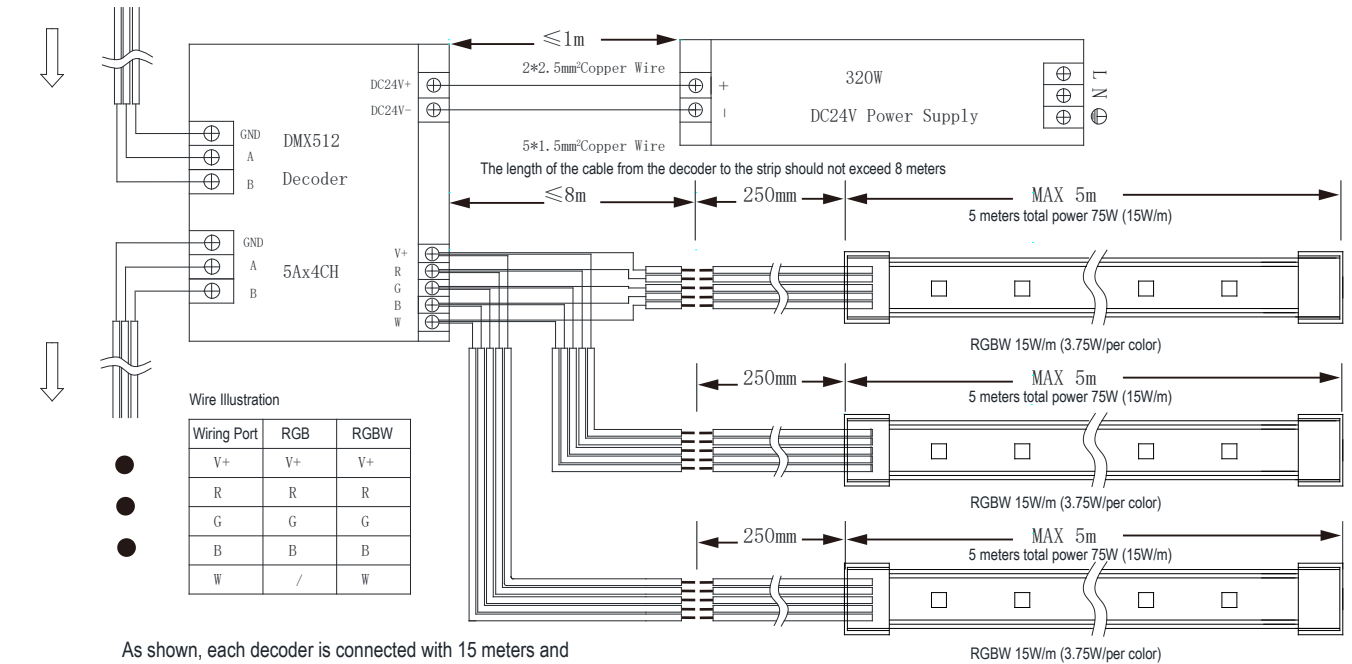

As shown, each decoder is connected with 15 meters and needs to be divided into 3 circuits with separate leads

5.

NOTES:

1. It is recommended to reserve 20% of the power supply. As shown, with 320W power supply, and 15W/m strip, the actual load is rounded to 15 meters instead of 17 meters.
2. It is recommended to reserve 20% for the decoder. As shown, each channel of the decoder is 5A, and each channel can be loaded $(24V \times 5A) \times 80\% = 96W$. For RGBW light with a single color of 3.75W, the maximum load can be 25 meters. Since the decoder is used in conjunction with the 24V driver, the minimum meters of the two should be taken, and the actual loading should be 15 meters.
3. When connection length of strip is over 5 meters, it should be led from another the decoder port.

6.

2. Wiring connections for RGB/RGBW/WWW with pixel control

CAUTIONS:
 There are input and output in the strip light, please connect the controller port to the input end
 There are arrow marks on the FPC board

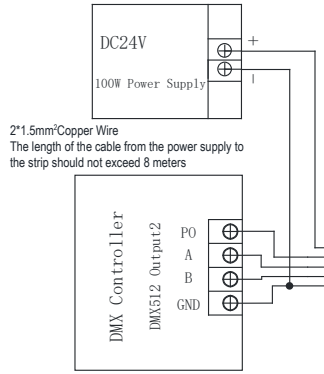

2*1.5mm²Copper Wire
 The length of the cable from the power supply to the strip should not exceed 8 meters

Wire Illustration between strip lights

The first strip light	The rear strip light	24V power supply
/	DC24V+	DC24V+
TO	TI	/
A	A	/
B	B	/
DC24V-	DC24V-	DC24V-

The DC24V+ of the front light strip and the rear light strip cannot be connected

Wire Illustration among power supply, controller and strip light

24V power supply	Connection Port	RGB/RGBW Strip light
DC24V+	/	DC24V+
/	ADRI/PO	TI
/	DMX+/A	A
/	DMX-/B	B
DC24V-	GND	DC24V-

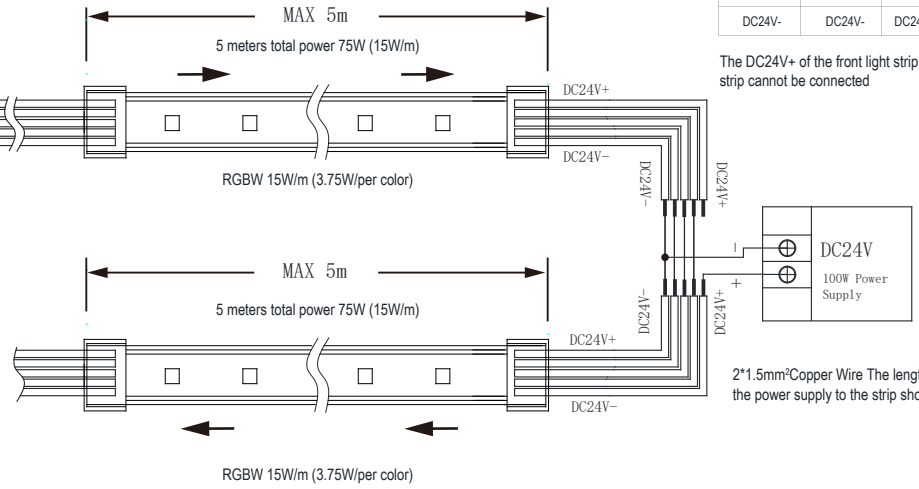

2*1.5mm²Copper Wire The length of the cable from the power supply to the strip should not exceed 8 meters

7.

8.

NOTES:

- 1、 It is recommended to reserve 20% of the power supply. As shown, with 100 power supply, and 15W/m strip, the actual load is rounded to 5 meters
- 2、 The maximum length of the light strip is 5 meters. If the length exceeds 5 meters, a separate DC24V power supply is required. For lights powered by different power supplies, DC24V+ cannot be connected together.
- 3、 The length of the light strip that the controller can carry is determined by the specifications of the controller
- 4、 Do not reverse input and output end when connecting

CAUTIONS:

- 1、 Turn off the power before installing or handling the product.
- 2、 Make sure the power supply and the strip light are firmly fixed
- 3、 Do not reverse polarity when connecting.
- 4、 Double check all connections before turning on power and the exposed wire ends need to be waterproof and insulated.
- 5、 It is recommended to reserve at least 20% of the power supply and non-isolated power supplies cannot be used

9.

Maintenance

- to ensure the stable use of the product and prolong its service life, regular inspection and cleaning is needed
- Cleaning and inspection at least every 3 months with power off

Inspection Method

- Whether driver and chips work well
- Whether there is unusual smell, sound or heat.
- Whether there are breakage, or looseness, etc. If an abnormality is found, please immediately power off and stop using, and eliminate the abnormality in time.

Cleaning

- Gently wipe the surface of the product with a soft, dry cloth to remove dust and other debris

10.